

# TECHNICAL GUIDE

**SEIKO**  
QUARTZ

CAL. 7430A  
CAL. 7431A  
CAL. 7439A

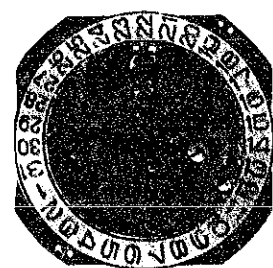

## CONTENTS

I. SPECIFICATIONS .....	1
II. STRUCTURE OF THE CIRCUIT BLOCK .....	1
III. DISASSEMBLING, REASSEMBLING AND LUBRICATING .....	2
1. Hour, minute, and second hands ~ center minute wheel .....	2
2. Coil block screw ~ crystal unit cushion .....	3
3. Train wheel bridge screw ~ stem with crown .....	4
IV. CHECKING AND ADJUSTMENT .....	5
• Check output signal .....	5
• Check hand setting condition .....	5
• Check battery voltage .....	5
• Check battery conductivity .....	5
• Check circuit block conductivity .....	5
• Check coil block .....	5
• Check gear train mechanism .....	5
• Check setting mechanism .....	5
• Check reset and train wheel setting conditions .....	6
• Check accuracy .....	8
• Check current consumption .....	8
• Check water resistance .....	9
• Check battery life indicator .....	9
• Check appearance and functioning .....	9

## I. SPECIFICATIONS

Item	Cal. No.	7430A	7431A	7439A
Time indication		2 hands	3 hands	2 hands
Additional mechanism		—	—	Date
		—	—	Instant date setting device
		Train wheel setting device		
		Electronic circuit reset switch		
	—	Battery life indicator	—	—
Loss/gain		Loss/gain at normal temperature range Monthly rate: less than 15 seconds		
Movement size	Outside diameter	φ22.4 mm (20.0 mm between 3 o'clock and 9 o'clock)		φ25.3 mm (21.7 mm between 3 o'clock and 9 o'clock, 22.0 mm between 6 o'clock and 12 o'clock)
	Casing diameter	φ22.0 mm		
	Height	2.1 mm without battery		2.3 mm without battery
Regulation system		Trimmer condenser		
Measuring gate by quartz tester		Any gate is available.		
Battery		SEIKO (SEIZAIKEN) TR721SW Battery life is approximately 3 years. Voltage: 1.55V		
Jewels		2 jewels		

## II. STRUCTURE OF THE CIRCUIT BLOCK

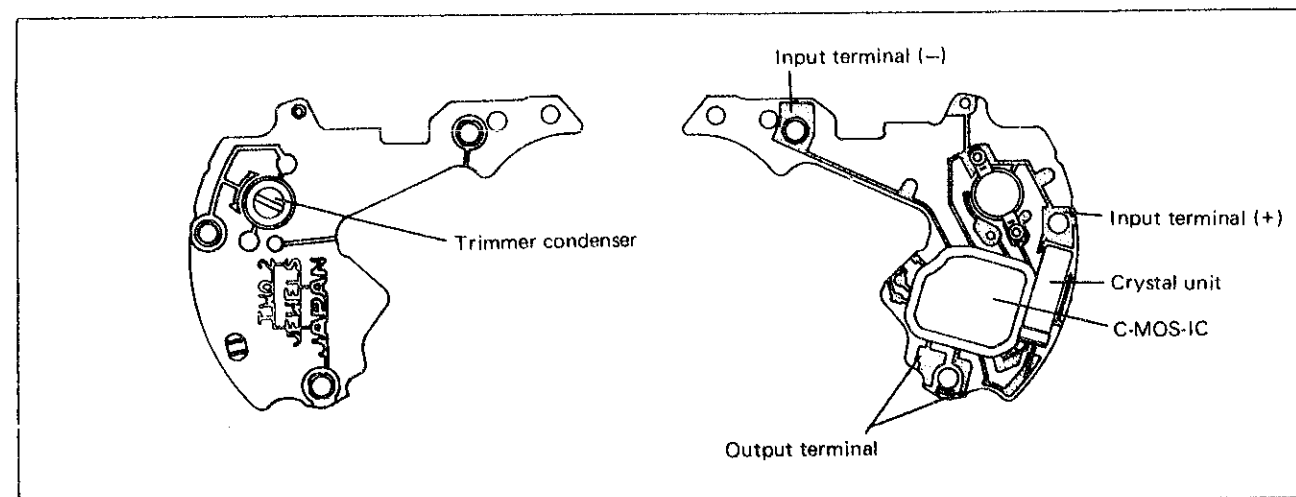

## III. DISASSEMBLING, REASSEMBLING AND LUBRICATING

Disassembling procedures Figs. : ① → ④③

Reassembling procedures Figs. : ④③ → ①

Lubricating:

Types of oil

● Moebius A

○ SEIKO Watch Oil S-6

Oil quantity

● Extremely small

● Normal

● Liberal

● Use the movement holder S-666 for disassembling and reassembling.

### 1. Hour, minute, and second hands ~ center minute wheel

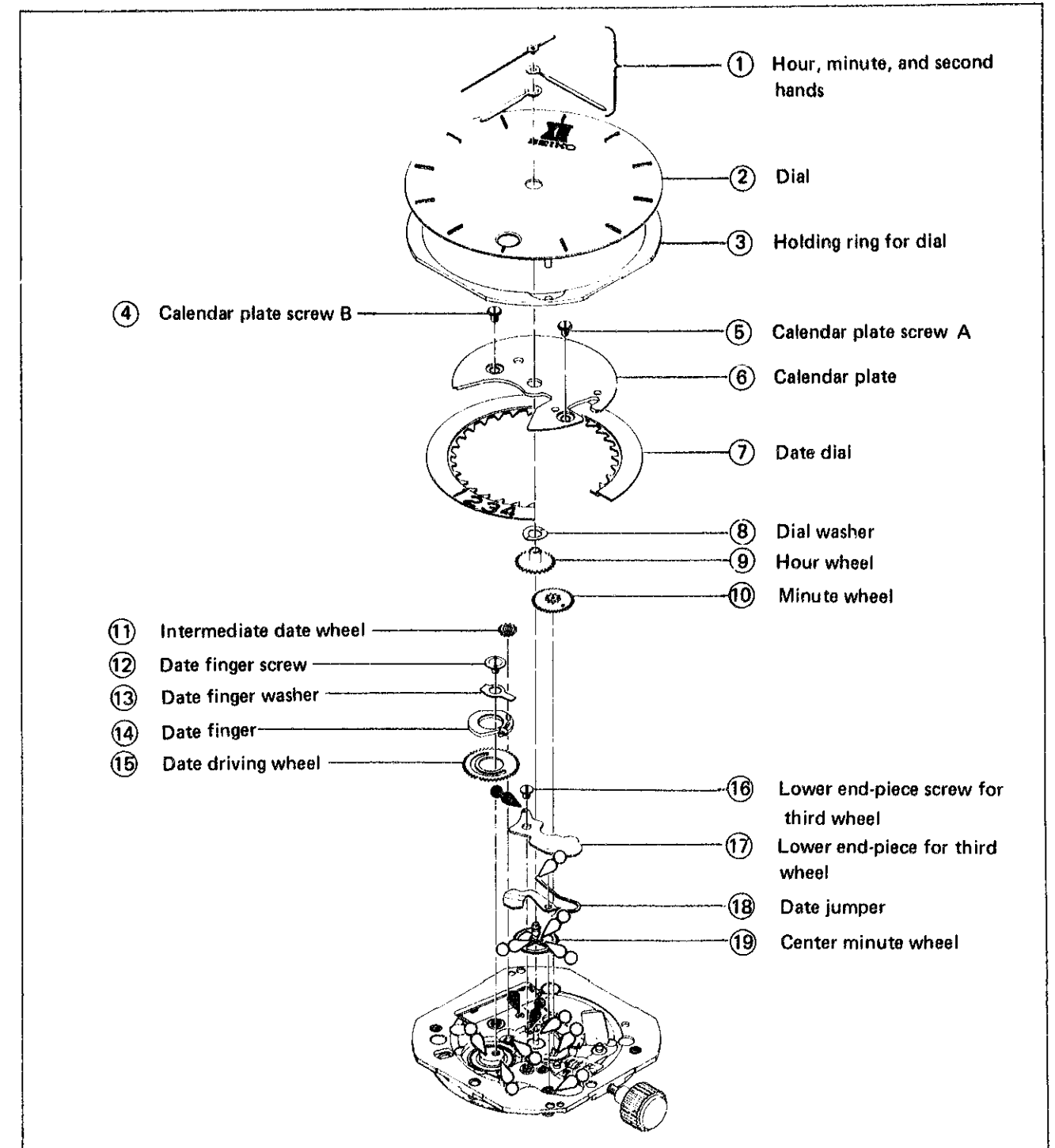

2. Coil block screw ~ crystal unit cushion

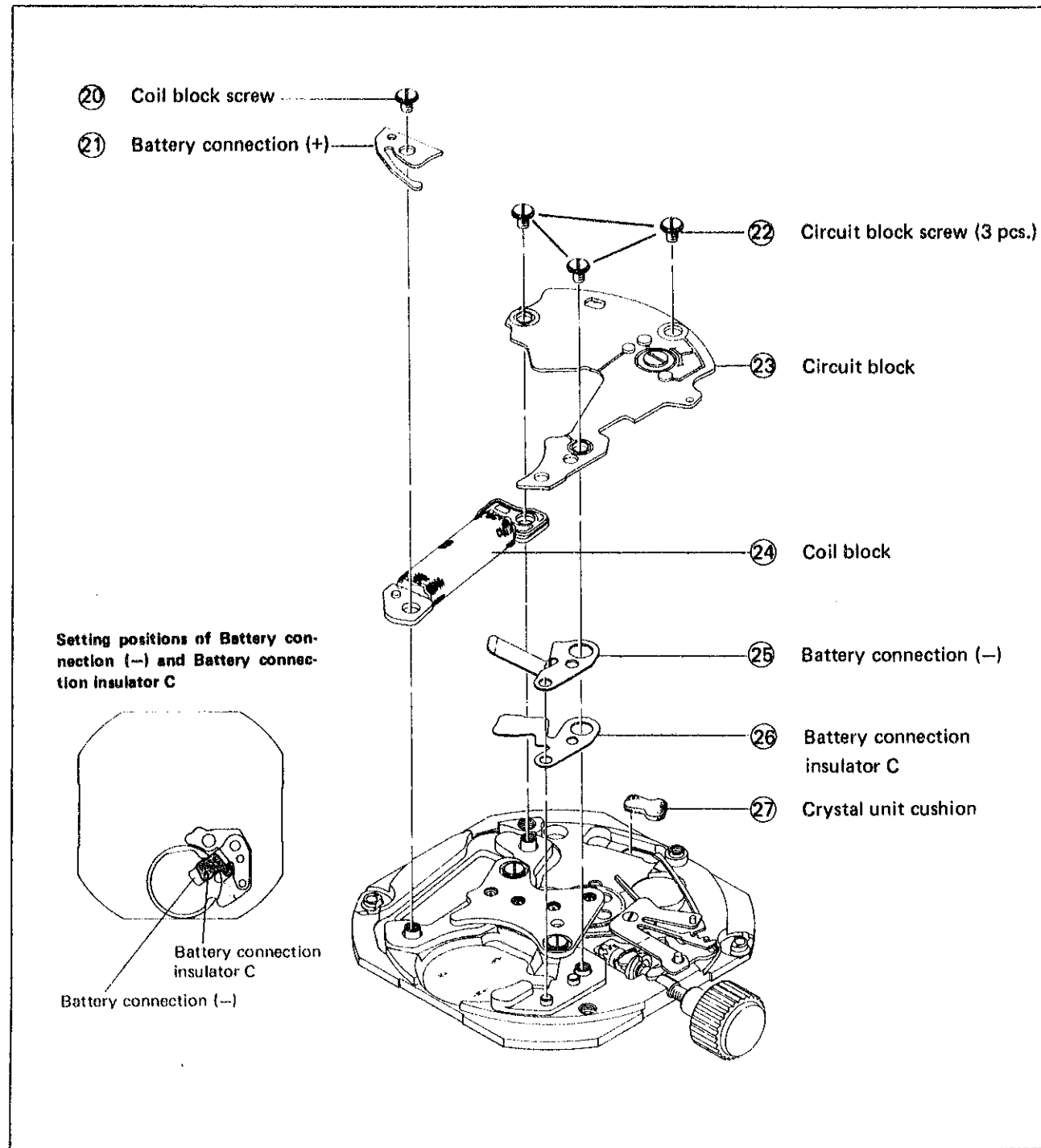



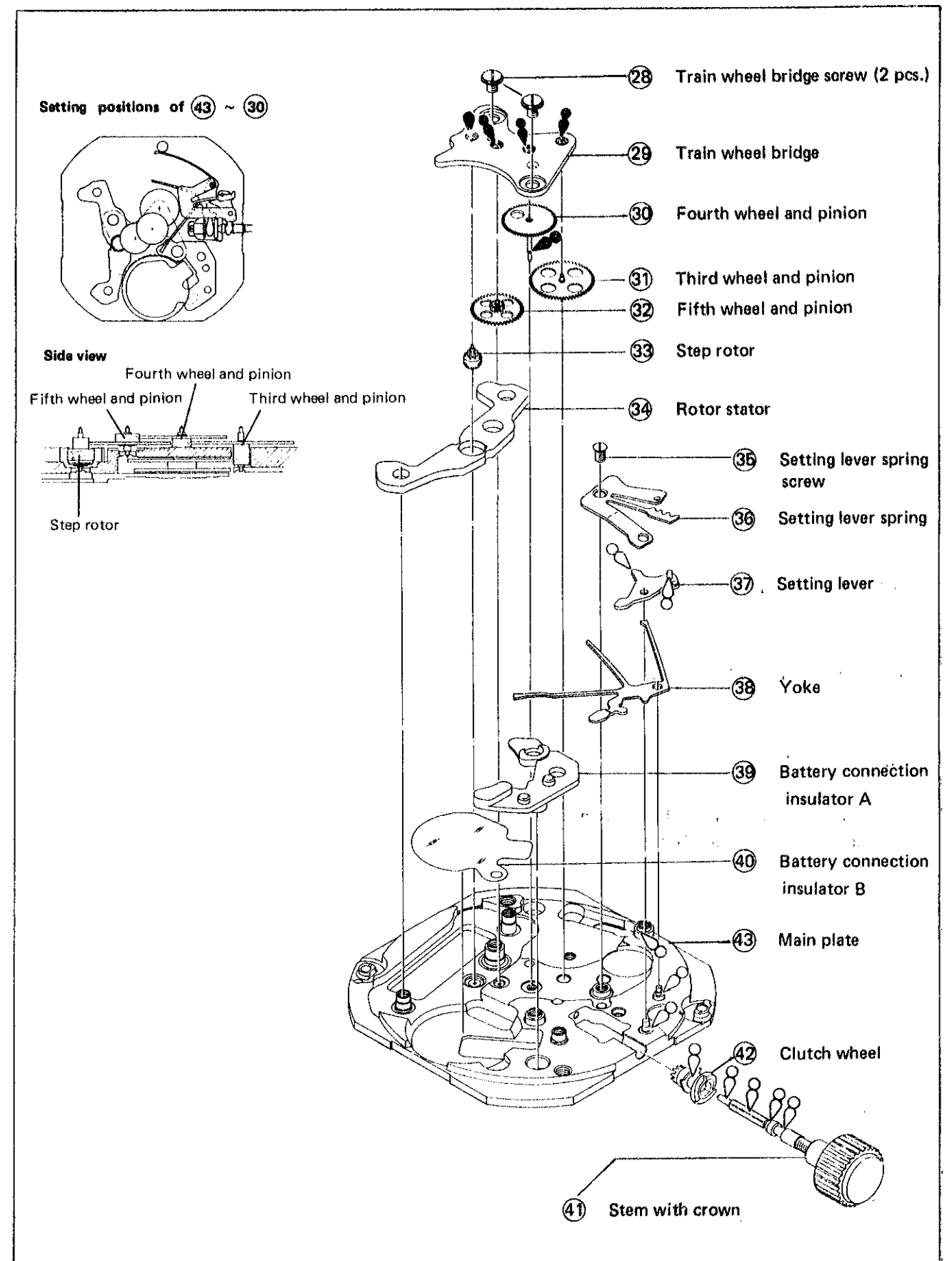

3. Train wheel bridge screw ~ stem with crown

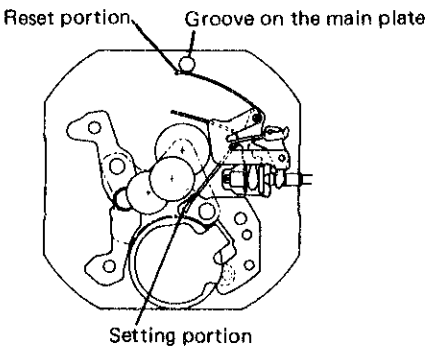
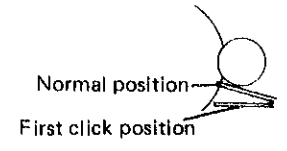

#### IV. CHECKING AND ADJUSTMENT

- The explanation here is particularly for the points of Cal. 7430A, 7431A, and 7439A.  
Refer to the "SEIKO QUARTZ TECHNICAL GUIDE, GENERAL INSTRUCTION" for analogue watches for details.

Procedure	
<b>CHECK OUTPUT SIGNAL</b>	<p>Use the electro-magnetic detection microphone. Any gate of the quartz tester is available.</p> <p><b>Result:</b> Normal: Input indicator blinks every second. Defective: Input indicator does not blink every second.</p>
<b>CHECK HAND SETTING CONDITION</b>	
<b>CHECK BATTERY VOLTAGE</b>	<p>Set up the volt-ohm meter. Range to be used: DC 3V</p> <p><b>Result:</b> Normal: More than 1.5V Defective: Less than 1.5V</p>
<b>CHECK BATTERY CONDUCTIVITY</b>	
<b>CHECK CIRCUIT BLOCK CONDUCTIVITY</b>	
<b>CHECK COIL BLOCK</b>	<p>Set up the volt-ohm-meter, and be sure to make a zero-ohm adjustment. Range to be used: OHMS x 100</p> <p><b>Result:</b> Normal: <math>2.7K\Omega \sim 3.7K\Omega</math> Defective: Less than <math>2.7K\Omega</math> (Short circuit) More than <math>3.7K\Omega</math> (Broken wire) Replace the coil block with a new one.</p>
<b>CHECK GEAR TRAIN MECHANISM</b>	
<b>CHECK SETTING MECHANISM</b>	

Procedure	
<b>CHECK RESET AND TRAIN WHEEL SETTING CONDITIONS</b>	
<p>1. Check the reset portion of the yoke. [ For the model with calendar ]</p> <ul style="list-style-type: none"> <li>• Crown at the normal and the first click positions</li> </ul>	<p><b>Result:</b> Normal: The reset portion is outside the groove.</p>
 <p>Reset portion, Groove on the main plate Setting portion</p>	 <p>Normal position First click position</p>
<ul style="list-style-type: none"> <li>• Crown at the second click position</li> </ul>	<p>Defective: The reset portion is inside the groove. Replace the yoke with a new one.</p> <p>Normal: The reset portion is inside the groove.</p>
	
<p>[ For the model without calendar ]</p> <ul style="list-style-type: none"> <li>• Crown at the normal position</li> </ul>	<p>Defective: The reset portion is outside the groove. Replace the yoke with a new one.</p> <p>Normal: The reset portion is on the circumference of the groove.</p>
	
<ul style="list-style-type: none"> <li>• Crown at the first click position</li> </ul>	<p>Defective: The reset portion is inside the groove. Replace the yoke with a new one.</p> <p>Normal: The reset portion is inside the groove.</p>
	
	<p>Defective: The reset portion is on the circumference of the groove. Replace the yoke with a new one.</p>

**Procedure**

**2. Check the train wheel setting portion.**  
[ For the model with calendar ]

• Crown at the normal and the first click positions

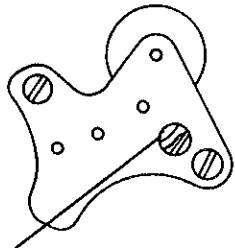

Inspection hole on the train wheel bridge

**Result:**

Normal: Clearance between the reset portion and the fourth wheel and pinion

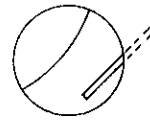

Defective: No clearance  
Replace the yoke with a new one.

• Crown at the second click position

Normal: No clearance between the reset portion and the fourth wheel and pinion

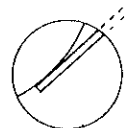

Defective: Clearance  
Replace the yoke with a new one.

[ For the model without calendar ]

• Crown at the normal position

Normal: Clearance between the reset portion and the fourth wheel and pinion

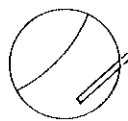

Defective: No clearance  
Replace the yoke with a new one.

• Crown at the first click position

Normal: No clearance between the reset portion and the fourth wheel and pinion

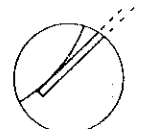

Defective: Clearance  
Replace the yoke with a new one.

**Procedure**

**3. After reassembling, check to see if the second hand stops promptly when the crown is pulled out to the second click position and if it starts promptly one second after the crown is pushed in back to the first click or the normal position.**

( Reset condition can also be confirmed by the procedure CHECK OUTPUT SIGNAL. )  
Crown at the second click position: Does not blink every second.  
Crown at the first click or the normal position: Blinks every second.

**CHECK ACCURACY**

**CHECK CURRENT CONSUMPTION**

Set up the volt-ohm-meter.  
Range to be used: DC 12 $\mu$ A

**Check current consumption for the whole of the movement.**

Probe red ..... Battery connection (-)  
Probe black ..... Battery (-) surface

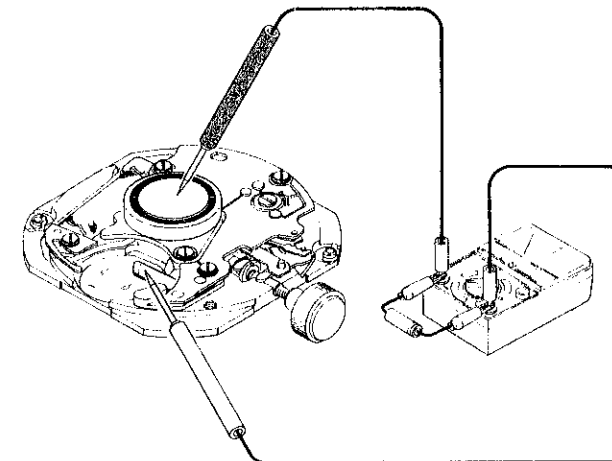

**Result:**

Normal: Less than 1.0 $\mu$ A  
Defective: More than 1.0 $\mu$ A\*

\* How to find defects when the current consumption is more than 1.0 $\mu$ A:  
Check current consumption of the circuit block alone.

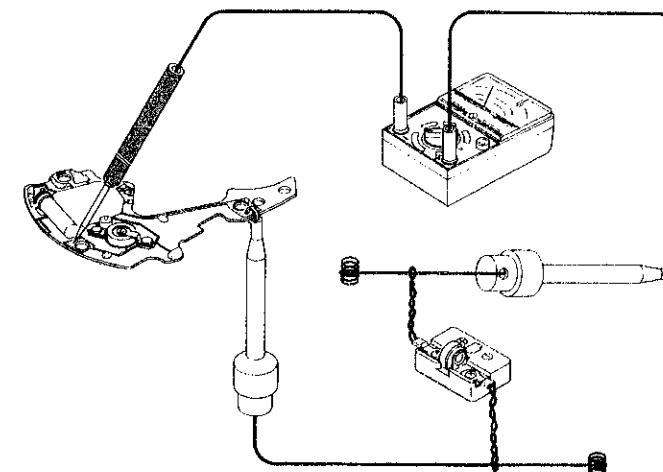

**Result:**

Normal: Less than 0.3 $\mu$ A  
Check the gear train mechanism.  
Defective: More than 0.3 $\mu$ A  
Replace the circuit block with a new one.

**Procedure**

**CHECK WATER RESISTANCE**

**CHECK BATTERY LIFE INDICATOR**

Set up the MICRO TEST and select the output voltage within the range of  $1.39V \pm 0.1V$ .

**CHECK APPEARANCE AND FUNCTIONING**

All procedures of Disassembling, Reassembling, Lubricating, Checking and Adjustment are completed.